

Realtime measurements of **particle-laden gas**



Self-cleaning precision orifice aerosol flowmeter

Aerosol Flowmeter

Measure gas flow rates, even when the gas contains aerosol particles

An invaluable tool for every aerosol lab, the Cambustion AF10 offers plug & play measurements of flow rates for improved experimental accuracy and repeatability.

Standalone operation, with support for interfacing and remote connections.



Key Features

- Wide range of measurable flow **0.1 – 10 lpm**
- Self-cleaning via integrated brush
- Compatible with solid, liquid & mixed aerosol flows
- Fully automatic temperature & pressure correction
- Traceable calibration certificate
- Touchscreen user interface
- Interfacing via analogue, Ethernet and USB

Flow measurement

Almost all aerosol experiments include a need to measure gas flows accurately, either to check that a measurement instrument is operating correctly, or to directly correct a measured parameter.

Many general laboratory methods exist for measurement of gas flow, including hot wire, rotameters, soap bubble, flying piston and more. However, none are ideal for aerosol laboratory use as they may variously be damaged by aerosol particles, have the flow reading affected by the aerosol particles, affect the aerosol itself through changes in humidity or temperature or impose pressure pulsations.

Aerosol flowmeter

The AF10 uses the well-established measurement principle of pressure drop across an orifice, with correction for absolute pressure and temperature.

Multi-orifice solution

Measurement of flow via orifice pressure drop has a poor “turndown” ratio — the range of flow rates that can be measured with good accuracy by a single orifice is typically only a factor of 3.

The AF10 offers the user four different sized precision orifices, whose flow rates overlap to cover the range 0.1 - 10lpm (a factor of 100).

Cambustion				Orifices
#	Max slpm	Dia (mm)	Serial	
1	3.40	1.000	111	↑
2	0.82	0.500	112	↪
3	1.89	0.750	113	× 1.00
4	7.76	1.500	114	↩

Selectable reference conditions

The AF10 simultaneously measures the volumetric flow (based on actual temperature and pressure) and also outputs the flow corrected to a set of reference conditions (temperature and pressure), which may be set by the user.

Straightforward operation

Simply turn the AF10 on and the user is immediately able to make flow measurements, with a colour touchscreen display visible from across the lab for those complex experimental setups needing adjustment.

Threshold alert

The user can set an alert if the flow deviates outside specified limits, or by a percentage from a nominal setpoint. The alert is both on screen and via a sound.

Touchscreen interface

With a USB power supply and a touchscreen for intuitive useability, the AF10 is an invaluable addition to any aerosol lab.

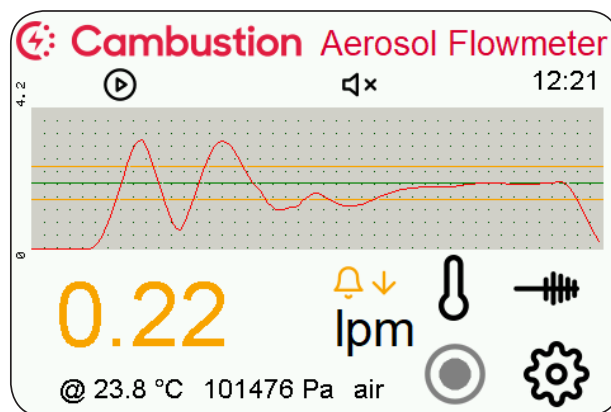

Minimally invasive

Many aerosol experiments involve a suction device such as a CPC drawing aerosol through a series of experimental stages. The overall pressure drop through the experiment must not exceed a threshold (typically 50mbar) to avoid errors on the CPC.

The AF10 uses precision sensors and user changeable orifices. The user may select an orifice to use all of the 50mbar sensor range, or select a larger orifice to reduce the pressure drop measured at a given flow.

This approach allows popular CPCs to draw aerosol through the AF10, while leaving “spare” pressure drop available for other parts of the experiment - live measurement of flows during the experiment becomes possible.

Low particle losses

Straight-through tube design minimises particle losses.

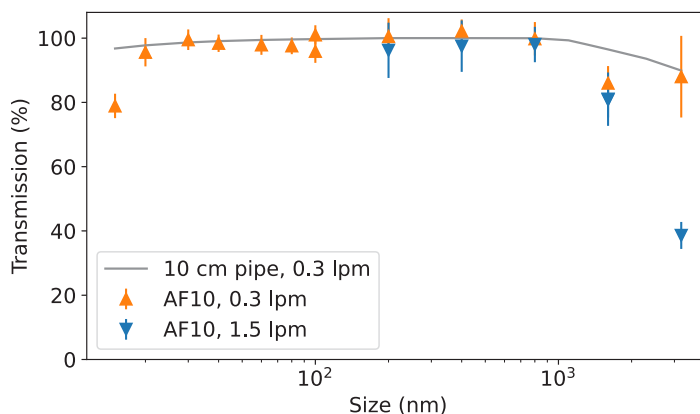

Application: Dilution bridge

Dilution bridges consist of a partial bypass of a HEPA filter and are a common and relatively inexpensive means to provide a high dilution of an aerosol. A widespread issue when using dilution bridges is that the valve exposed to aerosol flow clogs up as particles deposit, causing the dilution to increase over time.

Standard gas flowmeters would normally be placed downstream of the HEPA filter in the particle-free flow, but in high dilution applications, accurate measurement of the particle free flow does not allow accurate calculation of the bypass (aerosol) flow due to the large ratio between the flows. It is thus difficult to correct for drift without real-time knowledge of the bypass flow.

The AF10 can be used in dilution bridges to measure more accurately the dilution factor by monitoring the flow through the aerosol-laden branch directly, significantly increasing the accuracy in case of high dilution ($Y \ll X$).

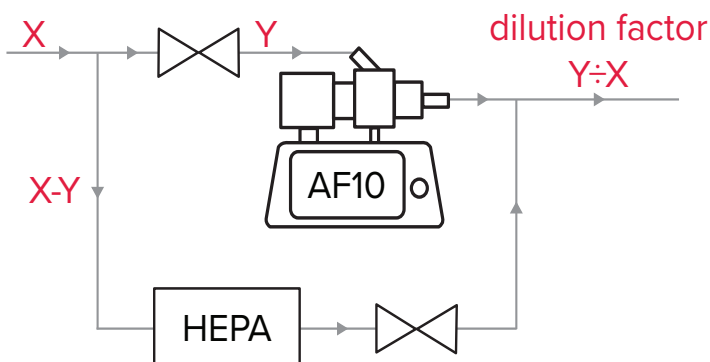

Why do flows matter in aerosol science?

- Many important metrics are expressed in terms of particles in a volume of gas ($\#/cm^3$ or $\mu g/m^3$).
- If the temperature or pressure change, the same mass of gas (containing the same particles) will occupy a different volume.
- Therefore, when comparing “per cm^3 ” measurements between different instruments, the cm^3 might be different if the conditions are not the same!
- Often it is assumed that a flow is fixed, but in real experiments flows drift – and affect measurements.

Consider a CPC measuring from an aerosol source with upstream dilution:

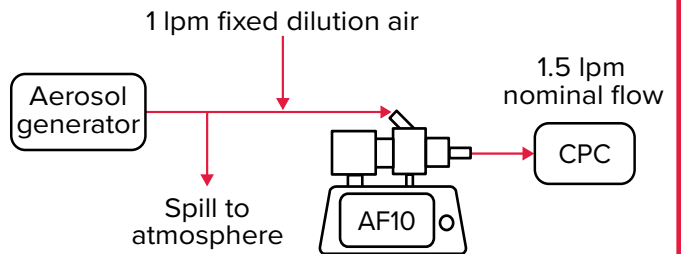

- A change in CPC flow will affect the measurement.
- Even if the CPC corrects its output to account for the flow difference, the upstream dilution will change and result in a measurement error.
- Real-time monitoring of the flow with the AF10 can be used to adjust the dilution flow as the CPC flow varies, or to calculate the true dilution.



The new Cambustion AF10 precision orifice aerosol flowmeter

Data logging

The user can easily log data to a USB flash drive for future analysis.

Easy interfacing

Interfacing via analogue output, USB and Ethernet is included as standard. The AF10 can also communicate directly with other Cambustion instruments including the AAC, CPMA & UDAC.

Easy cleaning

Depending on aerosol properties and the pressure drop across the orifice, material may build up on the orifice, affecting the calibration.

An integrated cleaning brush, actuated by a solenoid, removes accumulated material in less than 1 second, maintaining measurement accuracy even during prolonged experiments.

Cleaning can be manually triggered by the user, or based on time / external signals.

Robust for a range of environments

With all metal construction, the AF10 is at home in both laboratory and fieldwork environments, and can run from a USB power bank if needed.

Traceable calibration

Every AF10 is supplied with a traceable calibration certificate, ensuring the accuracy and traceability of your measurements.

Multi-gas compatible

The AF10 supports a range of common carrier gases, including air, nitrogen, argon and carbon dioxide (select gas in software for accurate measurements).

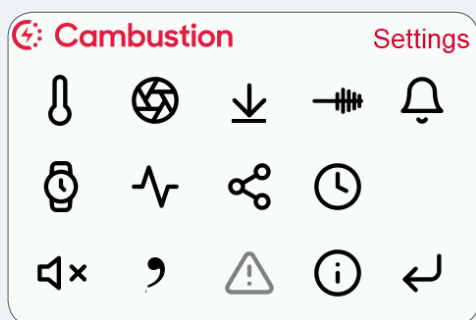

Specifications

Weight	<2 kg
Supported gases	Air, nitrogen, carbon dioxide, argon
Maximum operating altitude	2,500m
Aerosol properties	Non corrosive
Aerosol conditions	600 – 1,100 mbar absolute
Aerosol flow mode	Pressure or suction
Ambient conditions	+10 – +40°C (0 – 95% RH)
Max aerosol temperature	65°C
User Interface	Built-in touchscreen
Max pressure (invalid measurement, no damage)	0.5 bar gauge
Standard flow range (user changeable orifices)	0.1 – 10lpm
Data logging	To USB
Max data rate	10Hz
Interfaces	USB, Ethernet
Analogue output	0 – 10V (software configurable)
Electrical supply	USB C input connector 0.9A @5V / 4.5W
Dimensions (W×D×H)	16.9 × 19.1 × 12.3 cm
All specifications subject to review and change without notice	

Cambustion is an independent, privately owned company with headquarters in Cambridge, UK and customers in more than 30 countries worldwide

Cambustion continue to research & develop novel instrumentation, and now also offer Measurement Consultancy; helping our global clients to solve a wide range of particle and gas measurement issues.



To learn more, visit:

cambustion.com

or contact:

support@cambustion.com

Global HQ | UK

J6 The Paddocks
347 Cherry Hinton Road
Cambridge
CB1 8DH
United Kingdom

Tel. +44 1223 210250
US & Canada: 1-800-416-9304