



# CPMA

## Centrifugal Particle Mass Analyzer

Application Note: CPMA03v02

Use of the Cambustion CPMA as an absolute standard for aerosol mass

View more at [cambustion.com](http://cambustion.com)

## Use of the Cambustion CPMA as an absolute standard for aerosol mass

### Introduction

The Cambustion Centrifugal Particle Mass Analyzer (CPMA) is an aerosol classification instrument, which allows selection of pre-charged ultrafine aerosol particles *directly according to their mass:charge ratio*.

It may be considered an equivalent instrument for particle mass to the Differential Mobility Analyzer (DMA), which allows selection of particles according to their electrical mobility (drag:charge ratio).



The CPMA is used with an external pre-charger, which may be of the radioactive, X-ray or corona types.

The CPMA uses a balance between electrostatic and centrifugal forces to select particles of a given mass:charge ratio.

Novel features ensure a higher throughput of particles of the selected mass:charge ratio, compared with earlier instruments such as the Kanomax Aerosol Particle Mass analyzer (APM). [Ehara *et al.* (1996)]

The CPMA principle is described in detail in this animation:

<http://www.cambustion.com/products/cpma/animation>

### Using with an electrometer as an absolute standard

#### Theory

Strictly speaking, the CPMA classifies by mass:charge ratio, i.e.  $M_p/N_q$  where  $N_q$  is the number of discrete electronic charges. For most accurate results, charge correction should be applied. However, when an aerosol electrometer is used as a detector, true mass concentration can be obtained without any explicit charge correction [Symonds *et al.*, 2013].

An aerosol electrometer consists of a filtration device in a Faraday cage connected to an electrometer circuit (a very sensitive ammeter measuring current  $I$ ). By Gauss' Law, charged particles caught in the filter induce charges in the surrounding cage, which cause a current to be measured by the electrometer in proportion to the number of charges per second. A pump draws sample through the filter at a rate ( $Q$ , cc/s) set by a flow controller. It actually measures concentration of aerosol charge,  $N_q/cc$ :

$$N_q/cc = \left[ \frac{C}{e\$} \times \frac{\$}{cc} \right] = \left[ \frac{A}{e} \times \frac{s}{cc} \right] = \frac{I}{eQ} \text{ where } e \text{ is the elementary charge } 1.6 \times 10^{-19} \text{ C.}$$

Aerosol electrometers are often used to measure particle concentration, downstream of a DMA, assuming each particle possesses exactly one electronic charge, in which case  $N_q/cc \approx N_p/cc$ . However, if an aerosol electrometer is used downstream of the CPMA, and the indicated concentration is multiplied ("weighted") by the mass setpoint, then the number of charges cancels out to give absolute mass concentration:

$$N_q/cc \times fg/N_q = fg/cc.$$

The CPMA software can be configured to give its output function as a mass weighted concentration. If then used with an electrometer, the two instruments together form a useful mass concentration standard.

For example, any other instrument which gives an indication of *total* mass concentration may be calibrated by selecting particles with the CPMA, splitting the classified flow into the instrument under test and an electrometer, and comparing the response of the instrument under test with the output function (in mg/m<sup>3</sup>) of the CPMA.

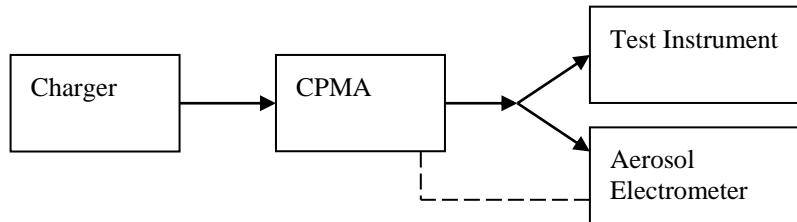

Note that it is the output function (in mg/m<sup>3</sup>) which is the key comparator; the mass setpoint, assuming a single charge ( $M_{+1}$ , in fg) of the CPMA is not directly relevant. This is because the instrument under test will measure *all* the  $M/n_q$  states from the CPMA, and thus it is not true that the selected calibration aerosol is monodisperse at the setpoint mass  $M_{+1}$ .

The *total* post CPMA mass concentration ( $m_{total}$ ) detected by a test instrument sensitive to true total mass concentration downstream of a CPMA set to a pass mass  $M_{+1}$  is:

$$\begin{aligned}
 m_{total} &= m_{+0} + n_{+1}M_{+1} + 2n_{+2}M_{+1} + 3n_{+3}M_{+1} + \dots \\
 &= m_{+0} + M_{+1}(n_{+1} + 2n_{+2} + 3n_{+3} + \dots)
 \end{aligned}$$

where the first term is the (perhaps unknown) zero charge mass concentration, and in each successive term  $n_q$  refers to the number concentration for  $q$  charges. The current measured by the electrometer is given by

$$\begin{aligned}
 I_{elec} &= Qe(n_{+1} + 2n_{+2} + 3n_{+3} + \dots) \\
 \therefore m_{total} &= m_{+0} + \frac{M_{+1}I}{Qe} = m_{+0} + M_{+1} \times \text{"Indicated N/cc"}
 \end{aligned}$$

for a flow  $Q$ , and  $e$  is the electronic charge. This shows that the *total mass concentration* measured by both the test instrument and given by the product of the CPMA mass setpoint and *indicated*<sup>i</sup> electrometer concentration should be the same, except for a necessary correction for zero charged particles<sup>ii</sup>.

However, this correction can be minimised to near zero by the use of a unipolar corona charger (as opposed to a bipolar charger), such as the Cambustion Unipolar Diffusion Aerosol Charger (UDAC) which will more efficiently charge particles, or by running at higher speeds (higher  $R$ ), or selecting aerosol from the leading edge of the underlying distribution (see Symonds *et al.*, 2013).

Note that the same is not true of a DMA-electrometer system – doubling “drag” does not double the concentration.

The concentration of particles which are uncharged can in any case be measured by use of an electrostatic precipitator (available from Cambustion), connected to a Condensation Particle Counter. When the precipitator is switched on, all the charged particles will be removed from the aerosol stream, and those remaining will be the uncharged population. From v1.60 of the user interface, if a “scan” is performed of an aerosol with a mass weighted output function selected then the Y-axis (and column D in the .cpma data file) is given in mass

<sup>i</sup> in that the indicated concentration given by an electrometer usually assumes a single charge i.e. it is  $I/Qe$

<sup>ii</sup> Negatively charged particles from a bipolar distribution will not normally pass through the CPMA at all

concentration terms (in mg/m<sup>3</sup>). This allows rapid calibration of an instrument by “scanning” over several values of  $M_{+1}$  and recording the average value of  $m$  at each point, for the desired averaging time.

### Practical implementation with a UDAC

In the scheme below, the CAFM (Cambustion Aerosol FlowMeter) and associated cabling is optional, but if present allows both the UDAC charging and CPMA resolution to be controlled more accurately (neither of which is critical for this application).

The charge neutraliser before the challenge instrument is also optional, but is strongly recommended as many challenge instruments may be sensitive to the large amount of charge imparted by the UDAC.

A Cambustion Electrostatic Precipitator and CPC can be used to quantify any uncharged particles – see Symonds *et al.*, 2013.

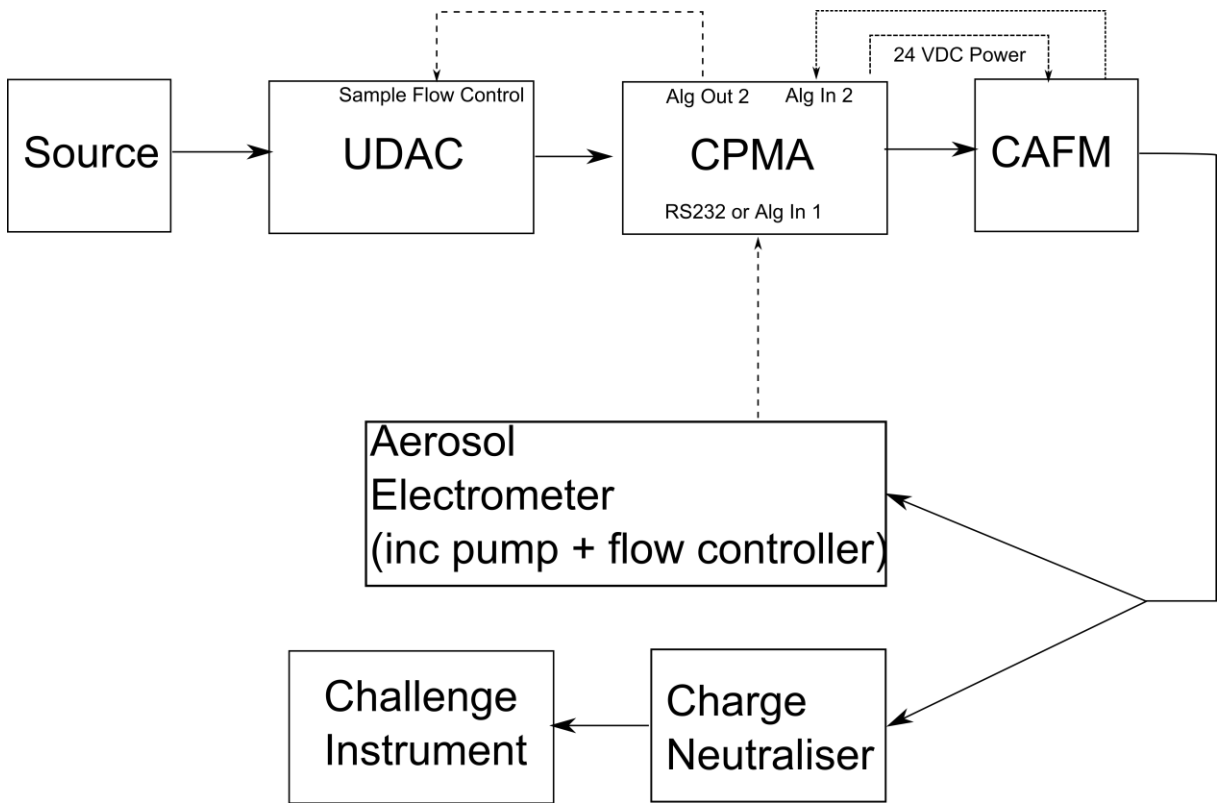

Set the output function of the CPMA to give mg/m<sup>3</sup> from the electrometer. This can then be read off the CPMA display or logged to an Output Function File.

### Further Reading

- CPMA: [www.cambustion.com/products/cpma](http://www.cambustion.com/products/cpma)
- DMS500: [www.cambustion.com/products/dms500/aerosol](http://www.cambustion.com/products/dms500/aerosol)
- Electrostatic precipitator: <http://www.cambustion.com/products/precipitator>
- UDAC: [www.cambustion.com/products/udac](http://www.cambustion.com/products/udac)
- Publications <http://www.cambustion.com/publications/pubinst/CPMA>

## Publications referred to in the text

- *Novel method to classify aerosol particles according to their mass-to-charge ratio — Aerosol Particle Mass Analyser.* K. Ehara, C. Hagwood & K.J. Coakley. *Journal of Aerosol Science*. Volume 27, Issue 2, Pages 217–234 (1996)

[http://dx.doi.org/10.1016/0021-8502\(95\)00562-5](http://dx.doi.org/10.1016/0021-8502(95)00562-5)

- *The effective density and fractal dimension of particles emitted from a light-duty diesel vehicle with a diesel oxidation catalyst.* J.S. Olfert, J.P.R. Symonds and N. Collings *Journal of Aerosol Science* Volume 38, Issue 1, Pages 69–82 (2007)

<http://www.ecd.bnl.gov/pubs/BNL-77708-2007-JA.pdf>

- *Diesel soot mass calculation in real-time with a differential mobility spectrometer* J.P.R. Symonds, K.St.J. Reavell, J.S. Olfert, B.W. Campbell and S.J. Swift. *Journal of Aerosol Science* Volume 38, Issue 1, Pages 52–68 (2007)

<http://www.ecd.bnl.gov/pubs/BNL-77814-2007-JA.pdf>

- *Mass–Mobility Measurements Using a Centrifugal Particle Mass Analyzer and Differential Mobility Spectrometer.* T.J. Johnson, J.P.R. Symonds, J.S. Olfert. *Aerosol Science and Technology*, **47**(11), pages 1215–1225 (2013)

<http://www.tandfonline.com/doi/abs/10.1080/02786826.2013.830692>